

Installation & Operations Manual

SmartCommand

32 Call Box System



2YEAR
WARRANTY

Pre-Installation Requirements

Table of Contents

Pre-Installation Requirements	Page 3
BOSS Internal Overview	Page 4
Typical System Layout	Page 5
System Installation & Wiring	Page 6
System Programming	Page 11
Call Commander Operating Instructions	Page 14
Power and Battery Monitoring	Page 17
Troubleshooting	Page 20
Specifications	Page 22
Appendix	Page 23

Required (Included):

- RATH Call Commander (Part #: 3200S, 3200F, or 3200D)
- USB programming cable
- USB flash drive with Configurator Software
- AC power cable
- 4-pin loop connectors
- 2-pin phone line connector



Required (Not Included) Sold Separately:

- RATH 3300 Series Call Boxes (Available from RATH by AVIRE)
- Power supply with battery backup (Part #: 1000) (Available from RATH by AVIRE)
- 18AWG, 4 conductor, 2 pair cable (Available from RATH by AVIRE)
 - Plenum Part #: RP7500094B
 - 2 Hour Fire-Rated Part #: 66120
- 120vac power
- Multimeter
- Windows based laptop (Windows 7 or greater required)
- Dedicated external phone line (if the system needs the ability to call off site)
 - Analog, Digital, VoIP, and Cellular (Rath Part Number 2100-LTEGSM4 and 2100-LTEVER4) supported.

NOTE: If using VoIP it must be converted to analog before connecting to the system.

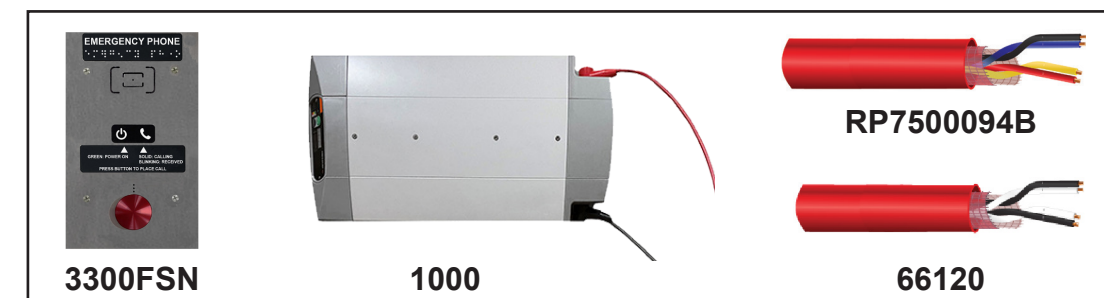

Brains of Smart System (BOSS) Internal Overview

BOSS Controller:

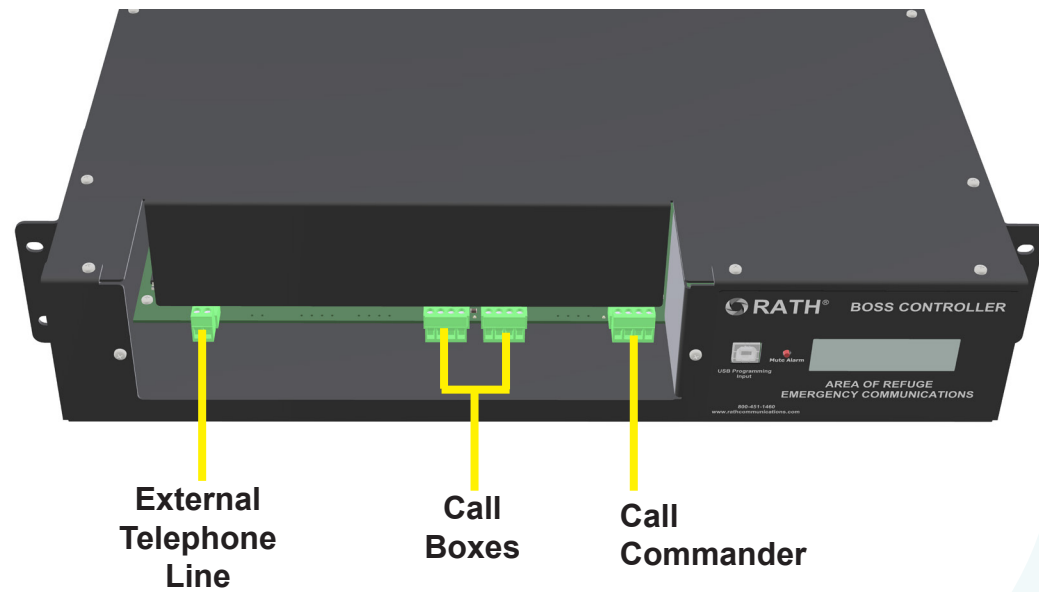

NOTE: To expose these connections, remove the two screws on the front of the housing to remove the cover.

Call Box:

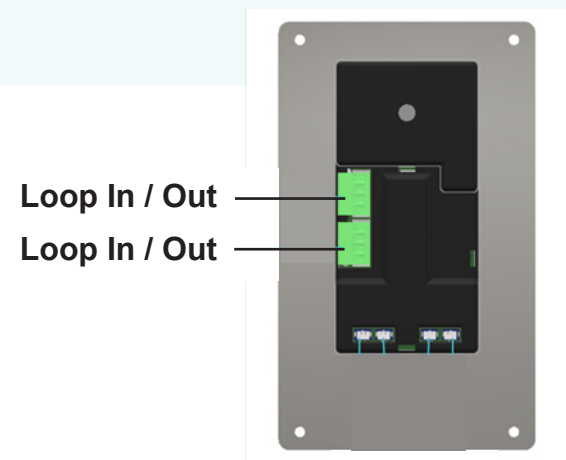

Call Commander:

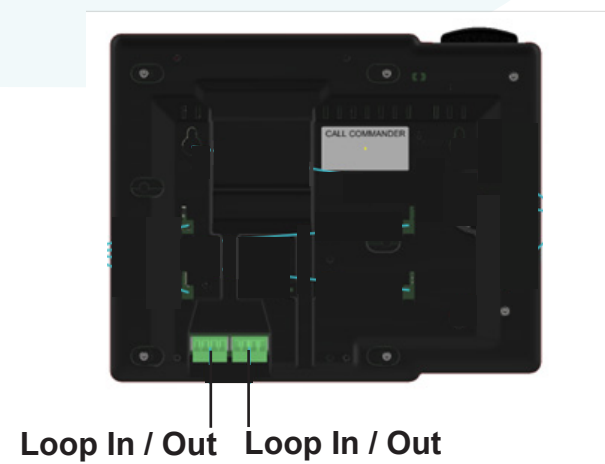

Typical System Layout

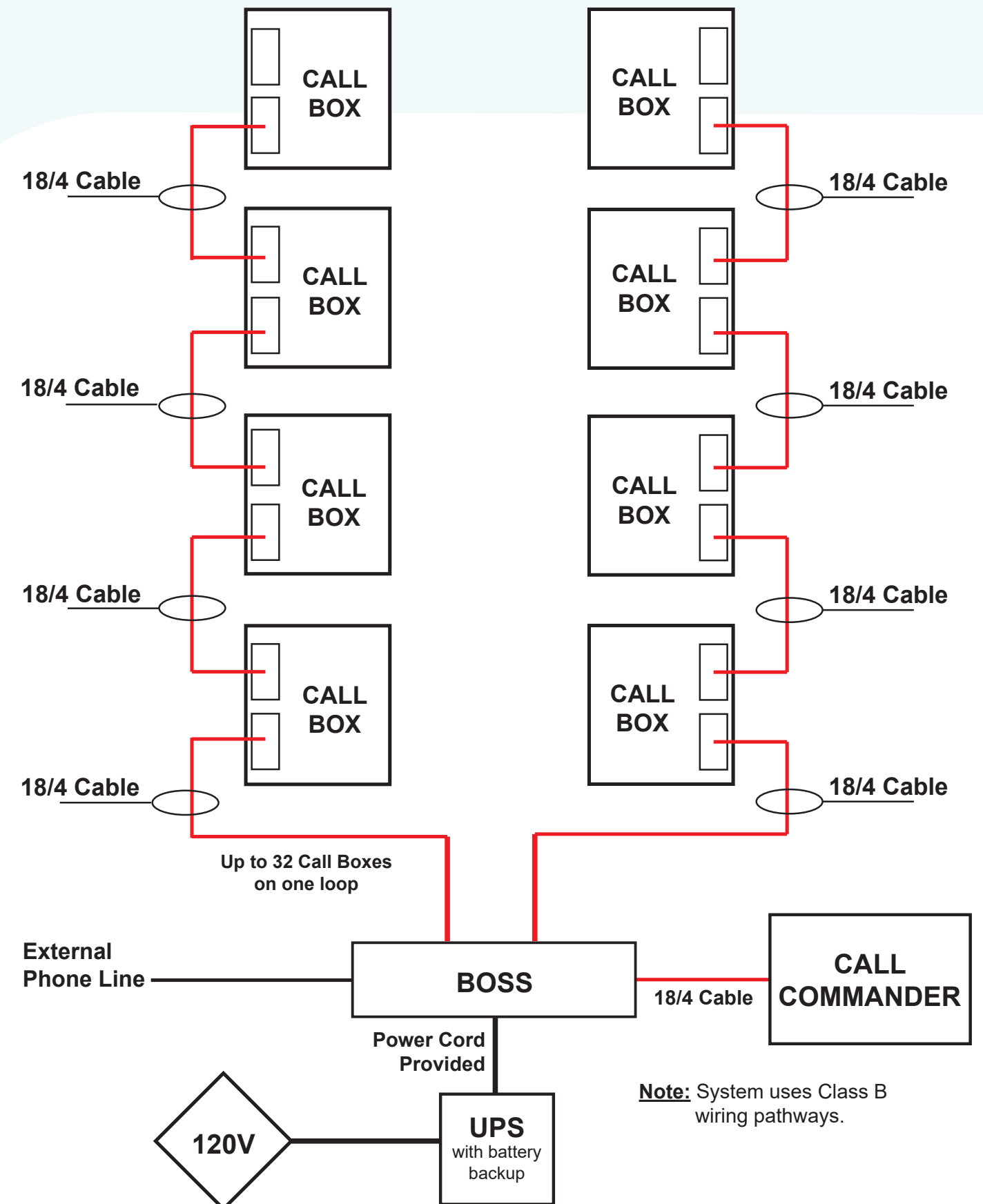

System Installation and Wiring

Powering the System

1. Mount the BOSS unit and power supply with battery backup in an appropriate location. The BOSS should be installed in a secure area with limited public access. A network closet or machine room is recommended.

NOTE: The BOSS can be rack mounted or wall mounted using the provided mounting arms.

2. Plug the power supply with battery backup into a standard 120v wall outlet.

NOTE: System is to be powered by 120v, 60Hz, AC outlet protected by a 15A maximum circuit breaker.

3. Using the provided power cord, plug the 3-pin female connector side into the power input next to the power switch on the back of the BOSS unit. Plug the male 3-prong side of the power cable into any of the open outlets on the power supply with battery backup. Wait to power on the BOSS unit until all connections are made.
4. If not already done, remove the two screws on top of the metal housing holding the connection cover in place.
5. Remove the cover to expose the internal terminal connectors.
6. Remove the knock-out on left hand side of BOSS unit to route cables through.

Call Commander Wiring

1. Install the Call Commander
 - a. **Desk Mount:** Install the included foot stand on the back of the Call Commander and place the Call Commander in the building owner or AHJ's specified location.
 - b. **Cabinet Mount:** Use the provided Allen Wrench to remove the back box or back plate from the Call Commander cabinet. Remove any applicable knockouts then mount the back box or back plate in the building owner or AHJ's specified location using appropriate mounting hardware. Wait to reassemble the cabinet until all wiring is completed.

2. Run an 18/4 cable from the Call Commander back to the BOSS unit.

NOTE: This cable provides communication and power. No additional power is required.

NOTE: The maximum wire run length from the Call Commander to the BOSS is 900 feet.

NOTE: Only one Call Commander can be used with the system.

3. On both ends of the 18/4 cable, strip back and expose 1/4" of wire on the individual conductors of the 18/4.

4. Route the cable through applicable knock-outs done as a part of step 1.
5. Screw the 4 wires from the 18/4 cable into the provided 4-pin loop connector following the wire scheme below. Verify the wires are seated fully into the connector and the screw terminals are firmly tightened down before moving on. Repeat for both ends of the cable.

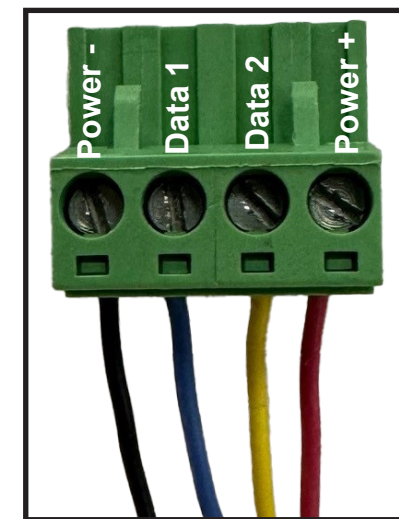

P/N: RP7500094B

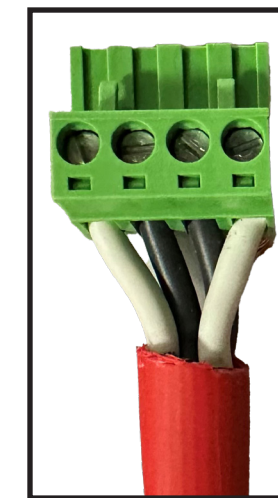

P/N: 66120

If using RATH66120 cable, follow the "1" and "2" printed on the insulation jacket around the wire. Recommended order is 1 White, 1 Black, 2 Black, 2 White.

6. Once both ends of the cable have the 4-pin loop connectors securely terminated, plug the end landed at the Call Commander into either of the green terminal plugs on the back of the Call Commander. Then, plug the side landed at the BOSS controller into port L1A on the BOSS. See below for detailed port labels on the BOSS.

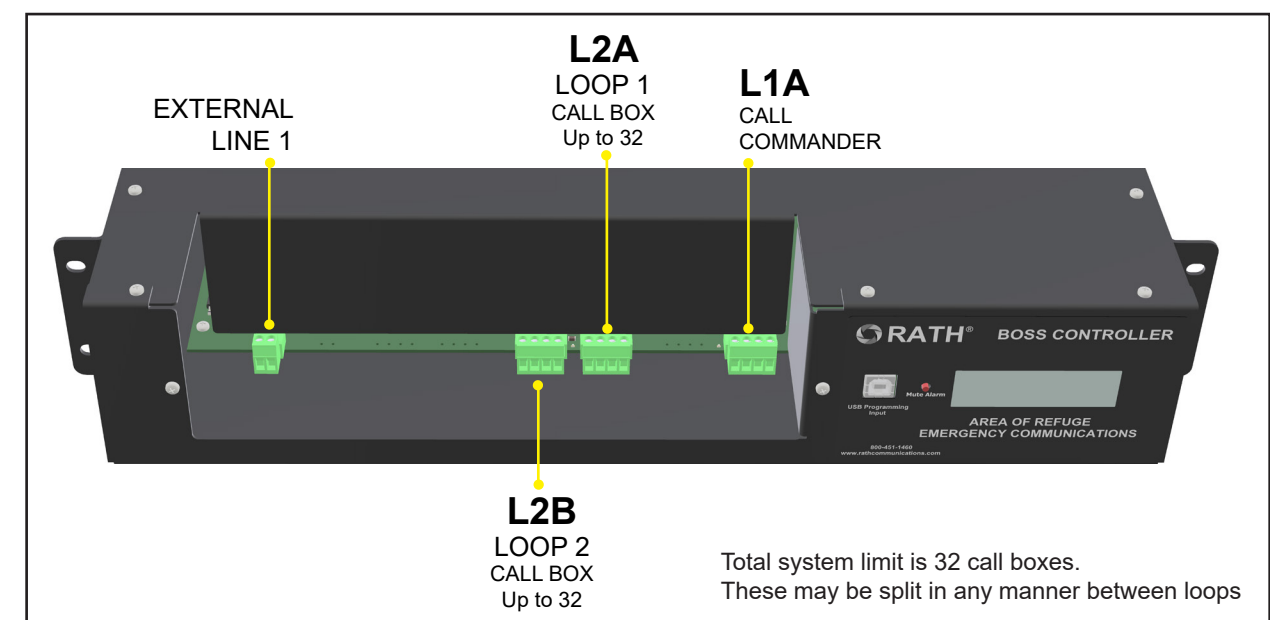

- If using a surface or flush mount Call Commander, install the cabinet faceplate back onto the back box and secure using the provided Hex screws and Allen wrench.

BOSS to Call Box Wiring

- Install the Call Boxes:
 - Surface Mount:** Remove any applicable knockouts in the back box to align with conduit ran to the call box mounting location. Mount the back box included with the surface mount call box in the building owner or AHJ's specified location using appropriate mounting hardware. Repeat for all call boxes.
 - Flush Mount:** Remove any applicable knockouts in the back box to align with conduit ran to the call box mounting location. Mount the flush mount back box (RATH part number: RP7700504) in the call box cutout in the wall. Repeat for all call boxes. Flush mount back boxes are sold separately and do not come with the call box.
- Run an 18/4 cable from the BOSS to the first Call Box.

NOTE: This cable provides communication and power. No additional power is required.

NOTE: Maximum wire length to the first Call Box is 650 feet.

- On both ends of the 18/4 cable, strip back and expose 1/4" of wire on the individual conductors of the 18/4.
- Route the cable through applicable knock-outs done as a part of step 1.
- Screw the 4 wires from the 18/4 cable into the provided 4-pin loop connector following the wire scheme below. Verify the wires are seated fully into the connector and the screw terminals are firmly tightened down before moving on. Repeat for both ends of the cable.

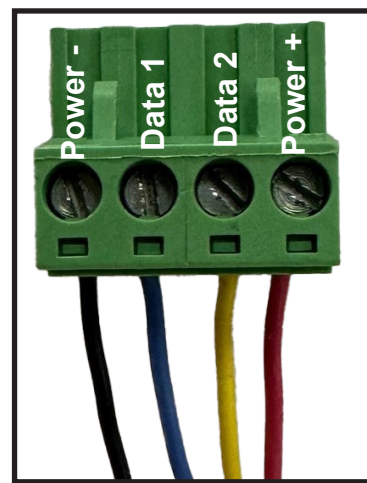

P/N: RP7500094B

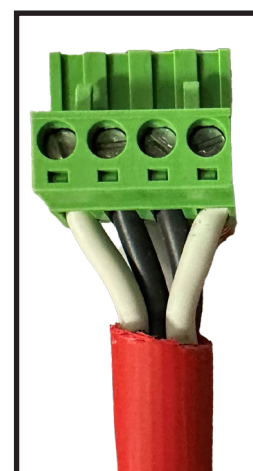

P/N: 66120

If using RATH® 66120 cable, follow the "1" and "2" printed on the insulation jacket around the wire. Recommended order is 1 White, 1 Black, 2 Black, 2 White.

- Once both ends of the cable have the 4-pin loop connectors securely terminated, plug the end landed at the first call box into either of the green terminal plugs on the back of the first Call Box. Then, plug the side landed at the BOSS controller into port L2A on the BOSS. See below for detailed port labels on the BOSS.

NOTE: Either connection on the call box can be used for input/output. It is recommended to always use the same port on each call box for the input and the other as the output for simplification purposes.

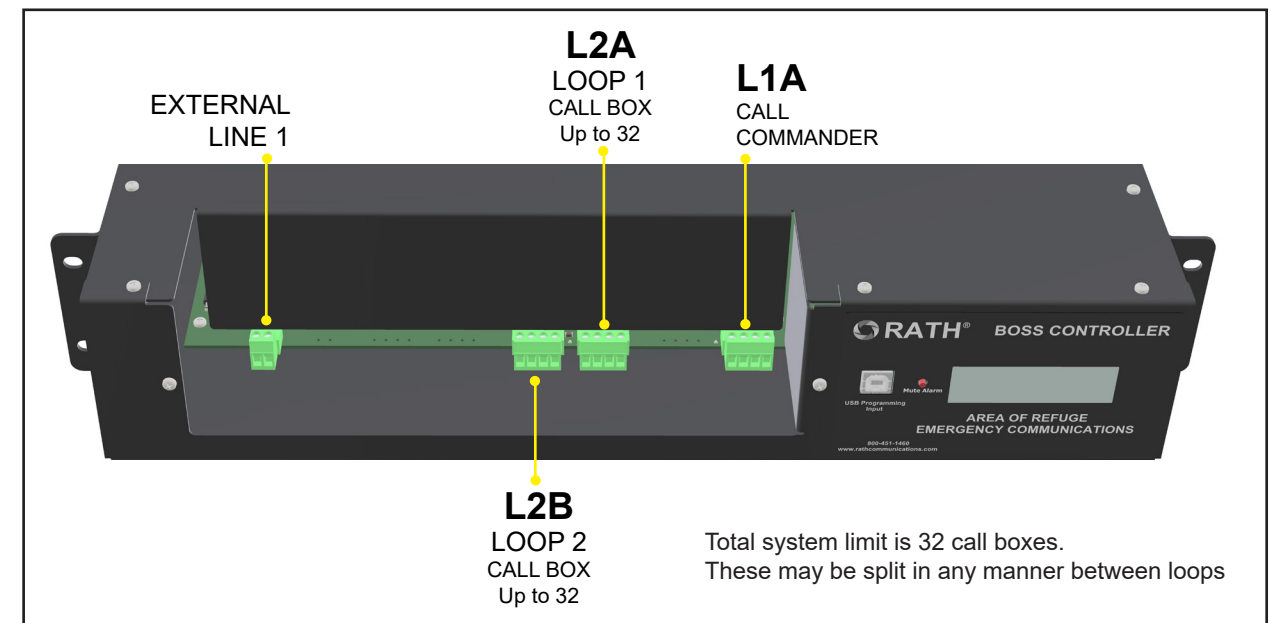

Call Box to Call Box Wiring

- Run an 18/4 cable from the first Call Box to the next Call Box in the loop.
- On both ends of the 18/4 cable, strip back and expose 1/4" of wire on the individual conductors of the 18/4.
- Route cable through applicable knock-outs done during back box mounting.
- Screw the four wires from the 18-4 cable into the provided 4-pin loop connector following same pin on page 8. Verify the wires are seeded fully into the connector and the screw terminals are firmly tightened down before moving on. Repeat for both ends of the cable.
- Once both ends of the cable have the 4-pin loop connectors securely terminated, plug the end landed at the first call box into either of the green terminal plugs on the back of the first call box. Then, plug the other end into either port on back of the second call box in the loop.

- Repeat for each call box until all call boxes in the loop have been terminated.
NOTE: Maximum wire run length between each Call Box is 650 feet.
NOTE: Maximum wire run length for a single loop is 2,000 feet.
NOTE: A maximum of 32 Call Boxes can be connected on a single loop.
- Connect remaining call boxes to L2B following the steps detailed in the BOSS to Call Box wiring section on page 8 and the Call Box to Call Box wiring section on page 9.
NOTE: Either connection on the call box can be used for input/output. It is recommended to always use the same port on each call box for the input and the other as the output for simplification purposes.
- Once all call boxes have been terminated, use the screws and torx bit included with the call boxes to mount the faceplate to the back box.

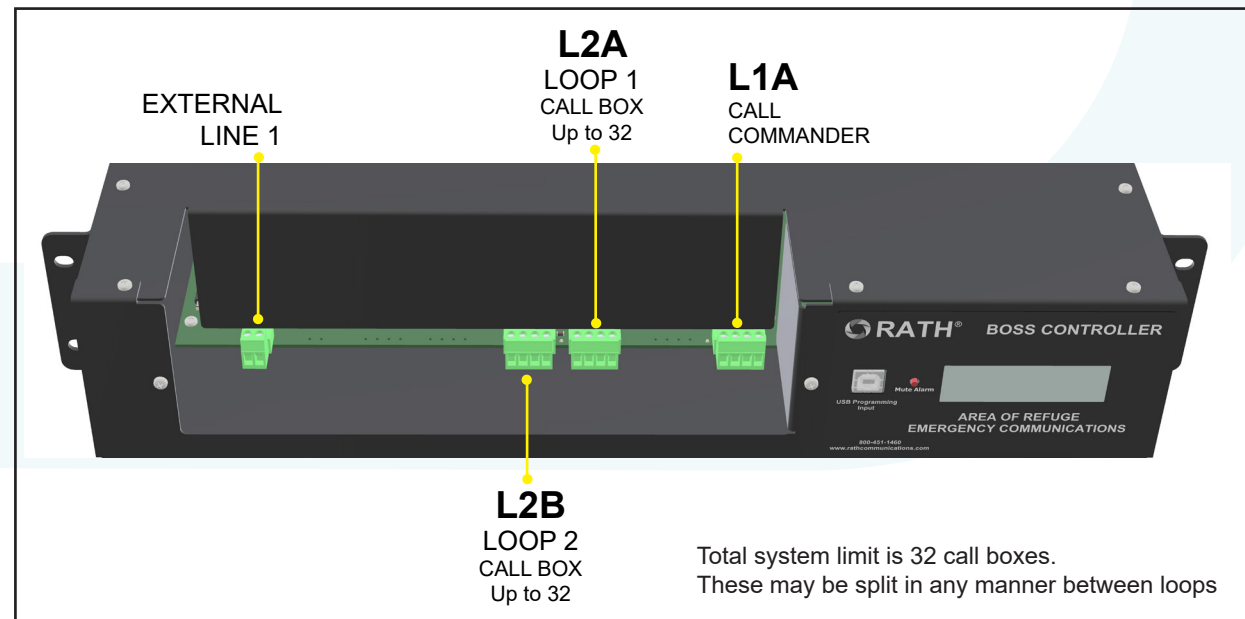

Dedicated Phone Line Wiring

- Connect the analog phone line or equivalent connection (cable modem, VoIP gateway, or cellular device) to the 2-pin screw terminal connector then connect it to the External Line 1 connection. The phone line input is not polarity sensitive.
NOTE: If using an external phone line with the system, it is recommended the line is verified and functional before connecting to the system. The phone line should have voltage, as well as dial tone. It is not recommended to use “ring-down” style phone lines with this system.

Powering on the System

- Screw the terminal connector cover back on to the front of the BOSS unit.
- Once all connections have been terminated, power on the BOSS using the power switch on the back of the unit. The Call Commander will start the boot process. While the Call Commander is booting, the BOSS should display the correct number of connected Call Boxes, one Call Commander, and the correct number of external phone lines. All call boxes should have the green power LED on the faceplate illuminated.
NOTE: If the information on the BOSS display is not correct upon start-up, there is likely a wiring or connection issue. Please power down the system and correct the issue before resuming setup of system.
- Upon first power up, the BOSS controller will sound its internal alarm due to lack of configuration. There will be multiple scrolling “SYS CONFIG XX” errors. Press and hold the mute button next to the display on the front of the BOSS controller for two seconds to silence the alarm. Once the configuration is complete, faults will clear automatically.

System Programming

- Before programming, verify the Call Commander has fully booted.
- Connect a laptop or PC to the BOSS using the provided USB cable. Plug the USB-B side of the cable into the USB-B port on the BOSS located to the left of the display. Plug the USB-A side of the cable into any open USB port on the laptop or PC.
- Plug the provided USB flash drive into any open USB port on the laptop or PC.
- Open the Configuration Software from the flash drive by double-clicking on it.
- Once the Configuration Software has opened, log into it using the following credentials:
Username: admin **Password:** password
- Once logged in, the Configuration Software will take you to the **Quick Start** screen to give an overview of the Configurator. Click the **Begin** button after reading. After clicking **Begin**, click **Connect** to connect to the BOSS unit. The connection may take a few minutes to complete. After connecting, the Configurator should show the correct number of connected Call Boxes, Call Commanders, and external phone lines.
NOTE: If configuration software shows incorrect information there is likely a wiring or connection issue. Please exit the configuration software, power down system, and correct the issue before resuming setup of system.
- Click the **Configuration** option on the left. The app will automatically go to the **General Information** menu and **System Information** tab.

8. In **System Information**, then **Edit Device**, type in the connected number of Call Boxes, Call Commanders, and phone lines, then click **Finish Edit**. A box will pop up asking you to confirm the information just entered.

NOTE: If what was entered does not match what is on the display of the BOSS, go back to **Edit Device** and correct. The two must match. The BOSS controller will go into fault and sound it's internal alarm if incorrect.

9. Click **Address Information**, then **Edit Device**, enter the address of where the system is installed, then click **Finish Edit**. (The system will use this information for the outbound message if calling off site)
10. Click **Telephone Information**, then **Edit Device**, enter the telephone number that the system will call out to if not answered at Call Commander. Up to two numbers can be programmed, one in the Number 1 slot, one in the Number 2 slot. Enter in the amount of time the Call Boxes will ring the Call Commander (in seconds) before the call will dial out to the external line next to **Ring Time**. If not doing a location message click **Finish Edit**, if doing a location message proceed to step 11.

NOTE: If two numbers are programmed into the system, the call will ring at the first number for 30 seconds before dialing the second number if the call is unanswered. .

NOTE: If system only needs to ring at the Call Commander set ring time to "0".

NOTE: Call Commander will continue to ring until call answered or joined at the Call Commander or hung-up by the external line.

11. If using a location message, while still in the **Telephone Information** tab, click the drop-down menu next to **Outbound Message Replay** to select if the location message will play once, twice, or continuous. Click **Finish Edit**.

NOTE: If the continuous option is selected, the message will play on a loop until the answering party hits any key on their telephone keypad to stop it. This option is recommended for all installations, especially for call centers that have a recording or a long wait before answering.

12. Click on **Call Boxes** in the **Configuration** menu.
13. Click on first Call Box listed then **Edit Device**, enter in the location or desired name of Call Box in **Location**, then click **Finish Edit**. There is a 16 character limit for names. (The system will use this information at the Call Commander as well as the outbound message if calling off site)
14. Repeat above steps for all Call Boxes until all show **Set** under status.
15. Click the **Outbound Message** tab in the menu on the left-hand side. This is only used if system is calling off site or at an in-building location other than the Call Commander. If calls are only ringing the Call Commander, skip to step 20.

16. Click the drop down next to **Message Voice** to change from male voice to female if desired.
17. In the message table, check the boxes next to all call stations that the message needs to be uploaded to.

NOTE: If uploading messages for the first time, make sure the first six boxes are checked for address information and operating instructions. Failure to do so may result in delays or an inability to answer an emergency call.

18. To hear an audio sample of each line, click **Click to Test**. If the pronunciation of the text needs to be modified, click on the call box that needs to be modified. Under **Update Audio** on the right, type in the corrected text, then click **Test**. For proper pronunciation, the auto may need to be typed out phonetically instead of using the accurate spelling to get the desired pronunciation. Once proper text is determined, click **Generate New** to save. Repeat for each line as necessary.

NOTE: Do NOT put any special characters in the Update Audio field. Spelling must be done with conventional letters.

19. After selecting all call stations, and adjusting audio if necessary, click the **Upload** button. Uploading will take roughly two minutes per message. Wait until all messages upload before clicking out of the message tab.
20. Once all configuration is complete, close out of the Configuration Software before testing by clicking the "X" / Close icon in the top right corner.

Optional Programming

System Time

1. Open the Configuration Software following steps 1-6 in the **System Programming** section on page 11.
2. Click **Settings** in the bottom left corner.
3. Next to time, the current system information will be displayed. Click **Sync Time**. This will sync the system time with the PC. Verify time on the PC is correct before syncing with the system.

System Fault

In the **General Information** tab under the **Configuration** menu there is the option for enabling power and battery monitoring on the system. By default this feature is disabled. To enable and for more information about fault monitoring, see page 17.

Factory Reset

Performing a factory reset on the system will remove all configuration done in the Configuration software and take the system back to factory defaults. To perform a reset perform the following:

1. While in the Configuration Software click **Settings** in the bottom left corner.
2. Click the **Factory Reset** button.
3. When the pop-up appears asking “Are you sure you want to perform a factory reset?” click **Yes**.
4. The BOSS controller and system will power down and re-boot. Wait until system fully boots before reconfiguring the system.

NOTE: It is recommended to close the configuration software and restart if performing a reset.

Call Commander Operating Instructions

In accordance with NFPA 72, the Call Commander has the ability to assign a call as “Urgent” or “Not Urgent”. Calls tagged as “Urgent” will have the highest prioritization after any unanswered calls. Calls are grouped within the call queue in the following order: not yet handled, urgent, non-urgent. Within each of those three groupings, calls are listed in the order in which they were placed. A call from a call box tagged as urgent would therefore only appear at the top of the queue if all of the other calls still in the queue were from call boxes tagged as non-urgent.

Answering a call at the Call Commander:

1. When the Call Commander is ringing, either lift the handset, press the **Hands-Free**, or **Select** button to answer the current highlighted call.
2. If multiple calls are coming in, press the **Hold** button to put the original call on hold. After putting the original call on hold, use the **Scroll Up or Down** button as required to scroll to the next desired call, then press the **Select** button. Repeat for any incoming calls.
3. To hang up the existing call, press the **Disconnect Internal** button or hang up the handset.
4. After disconnecting internal call, use the scroll up or scroll down button to assign the call as “Urgent” or “Not Urgent”, then press the **Select** button.

NOTE: It is recommended in an emergency situation to have high-traffic areas assigned as “Urgent”.

5. Repeat the steps above until all calls have been answered and the handset has been hung up if utilized.

Joining a call already in progress from the Call Commander:

1. Scroll to the desired call then press the **Select** button, **Hands-Free** button, or lift the handset to automatically join into the 3-way call.
2. Press the **Disconnect External** button to disconnect the external line.
3. Press the **Disconnect Internal** button to hang up the Call Box.
4. After disconnecting the internal call, use the scroll up or scroll down button to assign the call as “Urgent” or “Not Urgent”, then press the **Select** button.

NOTE: It is recommended in an emergency situation to have high-traffic areas assigned as “Urgent”.

5. Use the scroll up and scroll down button to select the next desired call.
6. Repeat the steps above until all calls have been answered and the handset has been hung up if utilized.

Call from Call Commander to Call Box:

1. Press the **Directory** button.
2. For a handset call, scroll to the required call box, lift handset, then press **Select**. For a hands-free call, scroll to the required call box, and press **Select** with the handset on-hook.
3. A handset call is ended by hanging up the handset. A Hands-free call is ended by pressing the **Disconnect Internal** button.
4. Press the **Directory** button a second time to exit the directory list.

Power Failure and Battery Fault Monitoring

The BOSS controller has built in external power and backup battery monitoring. To use this feature, fault monitoring needs to be enabled in configuration app (see page 18). Incoming power will be paralleled to the power fault input relay on the BOSS. The battery terminals from the RATH by AVIRE 1000 power supply will be paralleled to the battery input relay on BOSS. When in fault the System Fault Relay output will change state. This application is only recommended to be used with the RATH by AVIRE 1000 power supply.

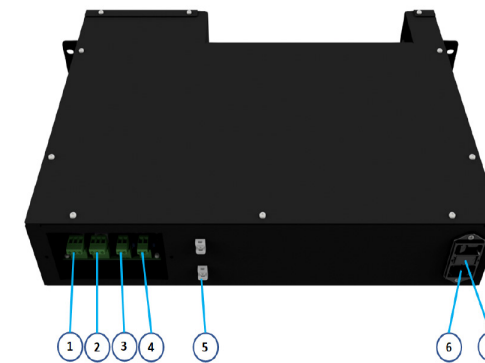

BOSS System Monitoring Hardware Overview

1. System fault relay output- Changes state when any fault occurs on system.
2. Call Box active call relay output- Changes state if any call box is attempting a call
3. Power supply fault input- Monitors Input Power
4. Battery fault input- Monitors Backup Battery
5. Cable strain relief
6. IEC power supply input
7. Power supply fuse

Broadcast a Message to call boxes from the Call Commander:

1. With the Call Commander handset hung-up press the **All Call** button.
2. Lift the Call Commander handset and press and hold the **Select** button. While pressing and holding the **Select** button, speak the desired broadcast message (Maximum 10 seconds), then release the **Select** button.
3. To review the recorded message, press and release the **Select** button.
4. To broadcast the message, hang up the handset and press the **Select** button.
5. The message will broadcast to four Call Boxes at a time until the message has been played at all Call Box locations. When the broadcast is completed, the Call Commander display will go back to its home screen for normal operation.

NOTE: During All Call, the Call Commander cannot answer an incoming call until message broadcast is complete.

Call Indicators at the Call Commander:

WTG- Call Waiting to be Answered

ACT- Active Call

HLD- Call on Hold

EXT- Call Box using External Line

3WY- Call Box in a Call with External Line and Call Commander

Adjust Volume on a Call Commander:

To adjust ringer volume: When the system is idle, press the **Volume** button on the Call Commander. Each time the **Volume** button is pressed, the volume setting on the Call Commander display will scroll through 0 to 3 (0 being lowest, 3 being the highest). This setting will be saved automatically.

To adjust handset volume: When the Call Commander is on a call, press the **Volume** button on the Call Commander. Each time the **Volume** button is pressed, the volume setting on the Call Commander display will scroll through 0 to 3 (0 being lowest, 3 being the highest). This setting will be saved automatically.

Wiring Diagram

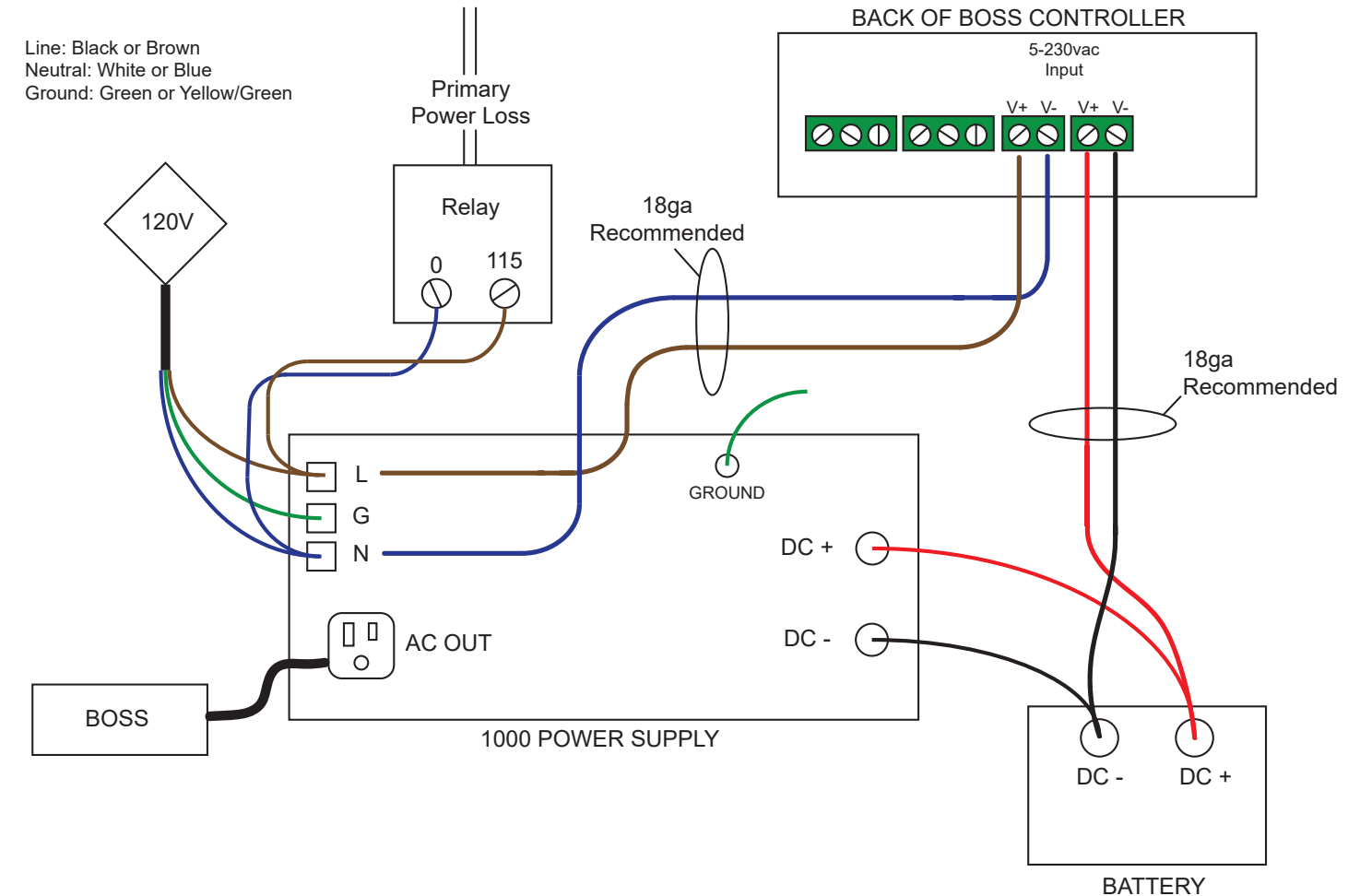

Power and Battery Fault Monitoring:

By default, fault monitoring of input power and battery on the system is disabled. To enable, perform the following:

1. Connect a laptop or PC to the BOSS using the provided USB cable. Plug the USB-B side of the cable into the USB-B port on the BOSS located to the left of the display. Plug the USB-A side of the cable into any open USB port on the laptop or PC.
 2. Plug the provided USB flash drive into any open USB port on the laptop or PC.
 3. Open the Configuration Software from the flash drive by double-clicking on it.
 4. Once the Configuration Software has opened, log into it using the following credentials:
Username: admin **Password:** password
 5. Once logged in, Click the **Begin** button to enter the **Quick Start** screen. Click **Begin** then **Connect** to connect to the BOSS unit. The connection may take a few minutes to complete.
 6. Click on the **Configuration** menu on the left.
 7. In the **General Information** tab, click on **System Fault Config**.
 8. Click **Edit Device**.
 9. Click the drop-down next to **Supply Fault Input** and select **Active Low**.
 10. Click the drop-down next to **System Fault Input** and select **Active Low**.
- NOTE:** Do not use **Active High** setting as it will trip when voltage is applied vs voltage lost.
11. Click **Finish Edit** to save.
 12. Close out of the Configuration Software before testing by clicking the "X" / Close icon in the top right corner.

Testing:

Power Loss: Unplug 110vac incoming power from 1000 power supply. Within 90 seconds the display on BOSS should show Supply Fault Input fault and system fault relay output should change state.

Battery Loss: Disconnect battery from 1000 power supply, when battery drops below 5vdc, within 90 seconds the display on the BOSS should show Battery Fault and fault relay output should change state.

NOTE: If the battery on the 1000 power supply is fully charged it may take up to 12 hours for the battery to drop below 5vdc.

System Fault Notifications:

As a part of the built-in system monitoring, the BOSS controller will fault if certain errors occur. When a fault occurs, the built-in sounder on the BOSS controller will sound and a fault code will appear on the BOSS's display. If there are multiple faults, display will scroll between them.

Explanation of System Faults:

- **System Fault** – Error signal detected on the alarm input monitoring the backup battery
- **Power Supply** – Error signal detected on the alarm input monitoring the power supply
- **Ground Fault** – There is a grounding fault in the installation wiring
- **Sys Config CC** – The number of Call Commanders connected does not match the configuration set in the Configuration App
- **Sys Config CB** – The number of Call Boxes connected does not match the configuration set in the Configuration App
- **Sys Config EL** – The number of external lines connected does not match the configuration set in the Configuration App
- **Loc:XXX CRC High**– Messaging errors detected on loop XXX, indicative of multiple possible connection issues on loop
- **Loc:XXX CRC Low**– Messaging errors detected on loop XXX, indicative of possible connection issues on loop
- **Loc:XXX a-x-b** – Loop break detected on loop XXX
- **Loc:XXX Amps Hi** – Overcurrent event on loop XXX
- **Loc:XXX Volts Hi** – Overvoltage event on loop XXX
- **Loc:XXX Volts Lo** – Undervoltage event on loop XXX
- **Lox:XXX Ext. Line** – Fault on external phone line XXX
- **Mic Fault** – The Call Commander has detected a fault on one of its microphones.

NOTE: Most faults will require a power cycle on the system to correct.

NOTE: To silence the sounder on the BOSS controller press and hold the **Mute** button to the left of the display for two seconds. This will silence the alarm for 24 hours or until the fault is resolved.

Troubleshooting

Problem	Possible Cause & Solutions
Can't connect to the Configuration Software:	<ul style="list-style-type: none"> • Make sure the Call Commander is fully booted before attempting to open the configuration software. • Verify the USB cable is plugged into a working USB port on the laptop or PC. • Verify the USB cable is seated fully in the USB port on the BOSS controller. • Close the software and power cycle the BOSS using the power switch on the back of the unit. After the Call Commander reboots, attempt to open the configuration software again. • The computer being used may not have a Virtual Com Port (VCP) driver installed. Either install a VCP driver on PC or try a different computer.
Call Commander won't power on or boot:	<ul style="list-style-type: none"> • Verify the Call Commander is connected to port L1A on the BOSS. • Verify the Call Commander is on its own loop. The Call Commander cannot share a loop with any Call Boxes. • Verify the outer pins of the wiring on the 4-pin loop connector. The pins should have 44-48vdc on pins 1 and 4. • Verify at least one call box is connected to the BOSS controller. The Call Commander will not boot without a call box connected.
Call Boxes won't call out to external line:	<ul style="list-style-type: none"> • Verify the phone line is connected to PSTN 1 on the BOSS. • Verify the phone line has 48-52vdc on it as well as dial tone. • Verify an analog phone can be connected to the line and can successfully place a call out to the number being entered into the configuration software. • Verify the connected phone line doesn't require an access digit such as an 8 or 9 to dial out.
BOSS not displaying the correct amount of Call Boxes after booting:	<ul style="list-style-type: none"> • Verify the Call Boxes have 44-48vdc on pins 1 and 4 of the terminal connector. • Verify the pin out of the 4-pin terminal connector on both ends. • Verify the wires are stripped back and fully seated in connectors. • Go to the last Call Box in the loop that the BOSS has recognized and verify the connector and the pin out to the rest of the loop.

Problem	Possible Cause & Solutions
Can't clear fault notification:	<ul style="list-style-type: none"> • Refer to the explanation of system faults list on page 19 to verify the fault type. • If the fault is for the external line, verify the line has active dial tone, voltage, and can place a call in and out. • If the fault is for a loop break, verify the wiring and pin out between the locations listed in the fault code on the BOSS display. • If fault is for over-current or under-voltage, verify the pin-out of the wiring between call boxes. Wiring should be connected in a daisy-chained scheme only. Wires cannot be spliced in to a loop. • Configuration faults will be due to a mismatch of the information entered into the configuration software and what is connected to the BOSS controller. • Verify no more than 32 call boxes are connected to a single loop. • See additional help with fault codes within this troubleshooting section.
Call Box has no power LED:	<ul style="list-style-type: none"> • Verify the call boxes are only connected to L2A or L2B. See page 7 for a detailed connection diagram. • Verify the pin-out of the 4-pin terminal connector. See page 7 for full pin-out details. • Verify the wires are seated into the terminal connector properly and secured firmly within the screw terminals. • Verify the wire in the terminal connectors is stripped back with minimal amounts of the raw wire conductor visible after securing. • Verify maximum loop length isn't being exceeded. A single loop cannot be more than 2,000 ft. • Verify the first call box is within 650 ft. of the BOSS controller. • Verify the call boxes have 44-48vdc on pins 1 and 4 of the terminal connector.
System has a Ground Fault Error Code:	<ul style="list-style-type: none"> • Verify no more than 32 call boxes are connected to a single loop. • Identify which call box is causing fault by looking for the first call box in the loop without it's power LED illuminated. Try swapping that call box with a known, good unit to see if issue follows call box. • Verify the wires in the terminal connector are not touching or broken off inside of connector. • Verify the wires going from call box to call box are truly daisy-chained with no wires spliced in that could break the loop.

Specifications

Connections

- Power | Public Switched Telephone Network (PSTN) | Battery Management System (BMS) Relay In/Out|USB Type B

Power Requirements/Protection

- 120v, 2.5A | Short Circuit, Overload, Over Voltage

Supervision

- Primary Power | Secondary Power | Telephone Line | Loop Monitoring

Operating Temperature

- Call Boxes: -13°F to 131°F (-25°C to 55°C)
- Call Commander: 23°F to 131°F (-5°C to 55°C)
- BOSS: 23°F to 131°F (-5°C to 55°C)
- For Indoor Use Only

Product Dimensions (W x H x D)

- BOSS: 17.20" x 12.59" x 3.46" (437 x 320 x 88mm)
- Call Commander: 7.95" x 9.84" x 2.91" (202 x 250 x 74mm)
- Surface Mount Call Box: 4.72" x 7.87" x 1.85" (120 x 200 x 47mm)
- Flush Mount Call Box: 5.11" x 8.66" x 3.62" (130 x 220 x 92mm)

Certifications

- UL 2525

FCC Disclaimer

This device complies with Part 68 and Part 15 of the FCC rules. Operation subject to the following two conditions:

(1) This device may not cause harmful interference and (2) This device must accept any interference received, including interference that may cause undesired operation.

FCC Reg. No: AW7AL01A8055 Ringer Equiv.:.01A

Telco Voltage

48-52vdc with at least 25mA of loop current and valid dial tone. Line must be dedicated for the system. Line must have an open-loop or CPC disconnect signal enabled.

Safety

- Do not expose to liquids or excessive humidity.
- Do not expose any of the components to fire.
- Do not try to modify any of the equipment.
- Do not use the equipment in hazardous areas.

Maintenance

It is recommended for the system to be tested monthly to verify operation. If call boxes are in need of cleaning, use a soft dry cloth. It is not recommended to use solvent or spray cleaners around the speaker and microphone holes.

Appendix A - BOSS Detail and Mounting

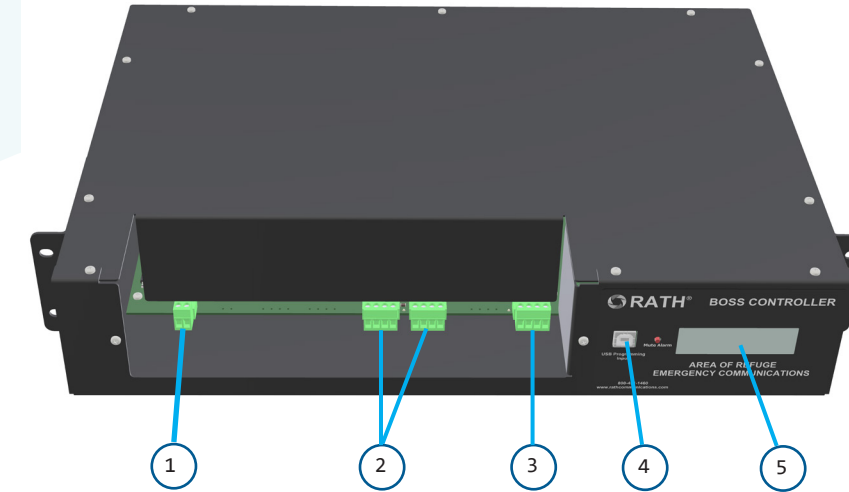

Front Components

1. External Phone Line connection
2. Call Box loop 1 and 2
3. Call Commander
4. USB programming input
5. System status display



Back Components

1. System fault relay output
2. Call Box Active Call relay output
3. Power supply fault input
4. Battery fault input
5. Cable strain relief
6. IEC power supply input
7. Power supply fuse

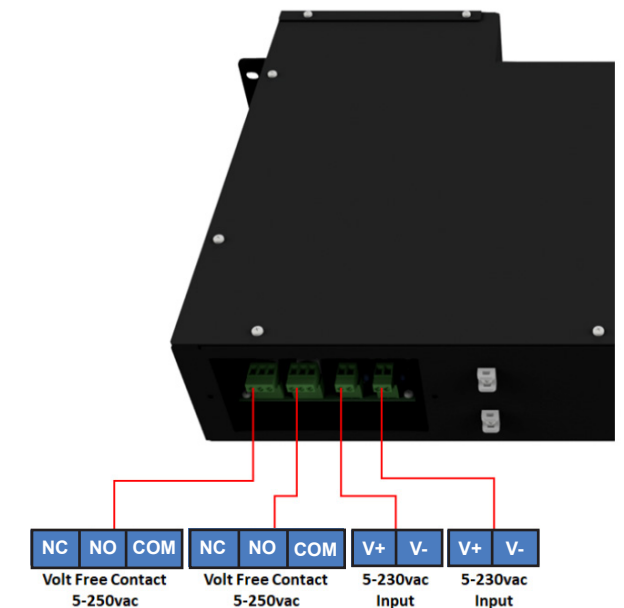

Appendix B- Call Box Detail and Mounting

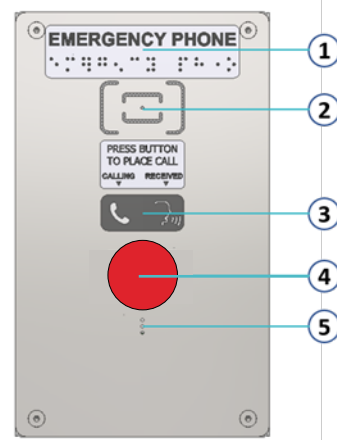

Call Box Front

1. Braille/emergency phone label
2. Speaker grille
3. Emergency call pictograms
4. Emergency call button
5. Microphone

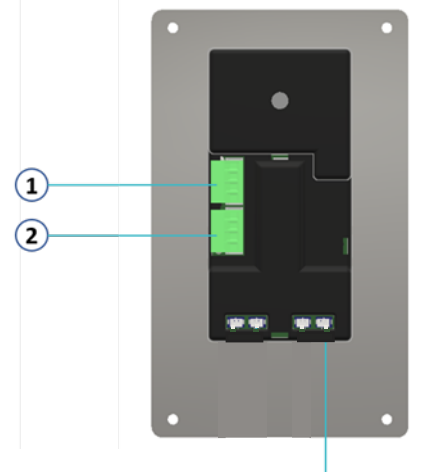

Call Box Rear

1. Loop input/output 1
2. Loop input/output 2
3. Call Button

Appendix C- Call Commander Detail and Mounting

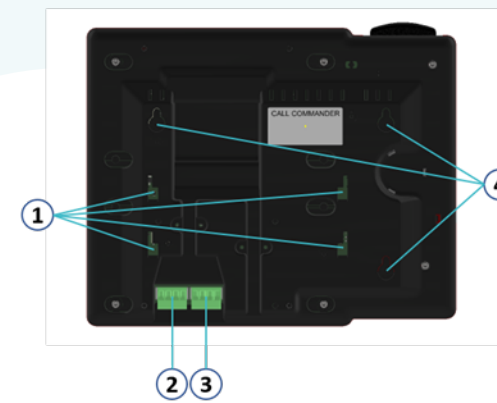

Rear & Side of Call Commander

1. Desk stand mounting clips
2. Call Commander input/output 1
3. Call Commander input/output 2
4. Wall mounting keyhole slots
5. Phone handset input



Front of Call Commander

1. Phone handset and hook switch
2. Hands-free speaker
3. Control buttons
4. 7 inch display
5. Software navigation buttons
6. Hands-free microphone

Flush Mount

The flush mount Call Box is designed to be mounted on to a standard 4 gang wall box.



Surface Mount

The surface mount Call Box can be fixed to any wall using the 4 keyhole slots in the metal back box. Cable entry points are on the top, bottom, and back of the enclosure.



Wall Installation



Cabinet Wall Installation

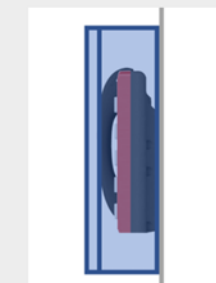

Desk Stand Installation





N56 W24720 N. Corporate Circle • Sussex, WI 53089 | 800-451-1460