

SmartView 2

Two-way Elevator Communication System



Product Datasheet

All-in-One Elevator Unit
7200



The **7200 All-in-One Elevator Unit** is a combined audio and visual communication system providing complete ADA compliance within the elevator car. The unit comprises of a display, camera, microphone, and speaker all within one compact housing. The SmartView 2 Elevator Unit also has inputs for the emergency call button and yes / no buttons to allow a trapped passenger to answer text messages that are displayed on the screen.

Note: The 7100 Machine Room Unit is required for installation.

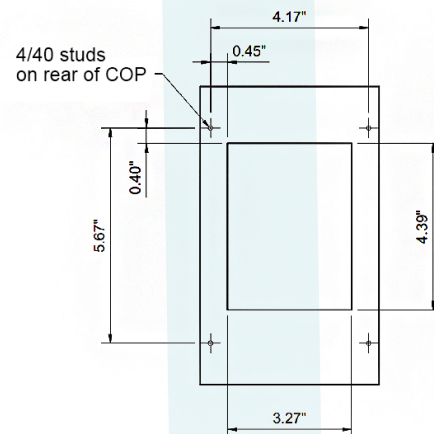

Machine Room Unit
7100



The **7100 Machine Room Unit** provides the conversion from twisted pair to Ethernet and POTS line and power to the SmartView 2 Elevator Unit. This is essential for connectivity of audio / video to the outside world. To function properly, the system requires one 7100 Machine Room Unit paired to one SmartView 2 Elevator Unit.

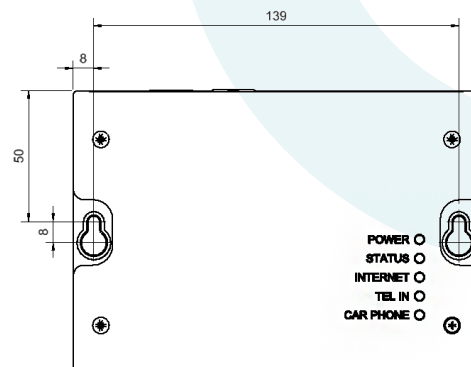

SmartView 2 System Components

Required in buildings where elevators travel beyond 60ft.



	Machine Room Unit	Elevator Unit	Lobby & Machine Room Unit with SmartView Display
Part Number(s)	7100	7200	Part numbers will vary
Dimensions	4.25" H x 6.10" W x 1.73" D	6.3" H x 4.65" W x 1.44" D	12-116 Zones (sizes vary)
Power	24 vdc	24 vdc (from machine room unit)	110 vac
Wiring	Connect via single pair		
Mounting	Wall mount	Behind the COP mount	Surface or Flush mount
Code Compliance	Conforms to ASME Standard A17.1 - 2019		
Warranty	2 year warranty for all components		
Optional Equipment	Ask about our cellular voice and data gateways & backup options		

SmartView 2 Two-way Elevator Communication System

Learn more



All-in-One, or Modular, Solution includes Voice, Video, Display and Monitoring

The SmartView 2 Two-Way Elevator Visual Communication System is designed to meet:

- ASME A17.1 2019/CSA B44-19
- IBC 2018
- ADA Compliant for the Hearing Impaired: Equipped with a visual system to ensure accessibility for all

+ Robust Security:

Encrypted software application provides ironclad protection to safeguard your elevator communication system

+ Seamless Integration:

Phone and visual system options significantly reduce installation time for effortless implementation

+ 24/7 Monitoring:

Have peace of mind knowing your system is monitored around the clock

+ User-Friendly Programmability:

Conveniently control and customize your system settings on site, in minutes



N56 W24720 N. Corporate Circle • Sussex, WI 53089 | 800-451-1460
www.avire-global.com/en-us/