

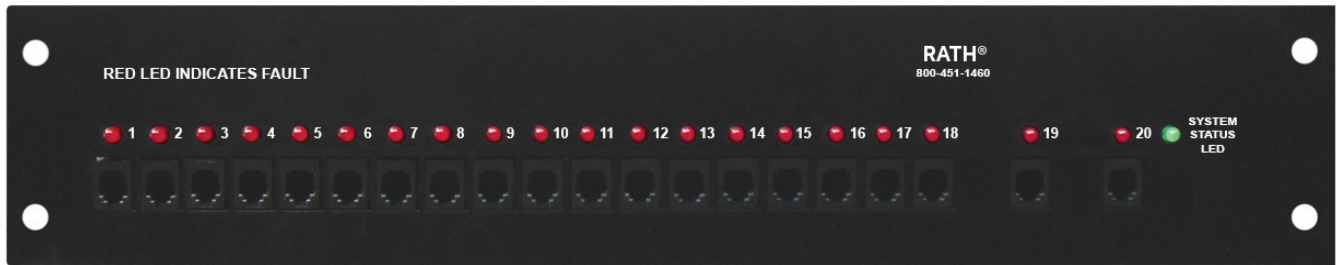

Installation & Operations Manual



Supervisor Board 2500-__SPRVSR



Thank you for purchasing a RATH® Supervisor Board. We are the largest Emergency Communication Manufacturer in North America and have been in business for over 35 years.

We take great pride in our products, service, and support. Our Emergency Products are of the highest quality. Our experienced customer support teams are available to remotely assist with site preparation, installation, and maintenance. It is our sincere hope that your experience with us has and will continue to surpass your expectations.

Thank you for your business,

The RATH® Team

Table of Contents

Items Needed	Page 3
Installation & System Wiring	Page 3
Connecting the Power Supply	Page 7
Setting Switches	Page 8
Alarm Wiring	Page 8
Mounting	Page 8
Complete System Connections	Page 8
Testing	Page 9
Typical System Layout	Page 9

Items Needed

Included:

- 2500-__ SPRVSR Supervisor Board(s)
- 4 pair RJ11 pigtail cables (quantity based on model number)
- 12vdc power transformer

Not Included:

- 110 style punch tool
- Distribution Module (sold separately with Command Center Base Station)
- RJ45 wiring pigtail cables (included with Distribution Module)

Installation & System Wiring

1. Swing out the Supervisor Board from the mounting bracket by removing the two screws on the left.
2. Take the RJ45 pigtail cables provided with the Distribution Module and plug them into the RJ45 jacks on the Distribution Module.
3. Use a 110 style punch tool to attach the pigtail side of the the RJ45 harnesses to the punch down blocks on the back of the Supervisor Board. Refer to the wiring diagrams below for the scheme used on the punch down blocks and Distribution Module.

Wiring 12-36 Zone Systems

For 12-16 zone systems, one Supervisor Board is included. Wire as shown below:

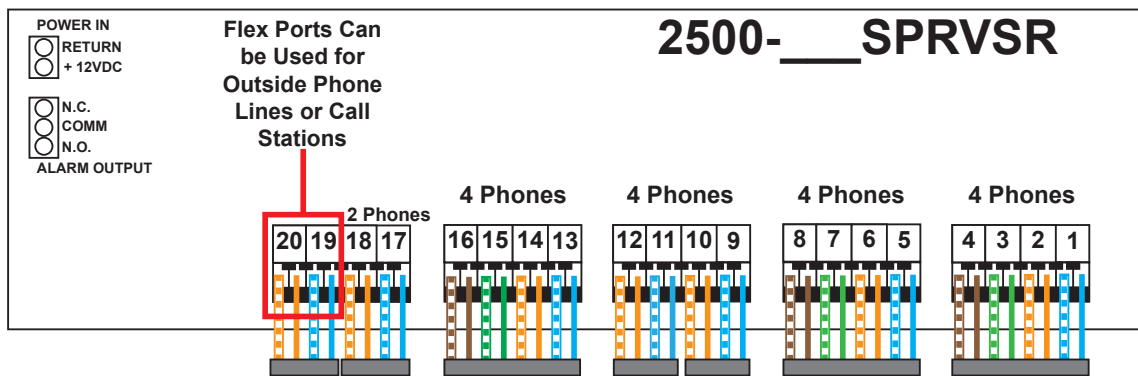

For 28-36 zone systems, two Supervisor Boards are included. Wire as shown below:

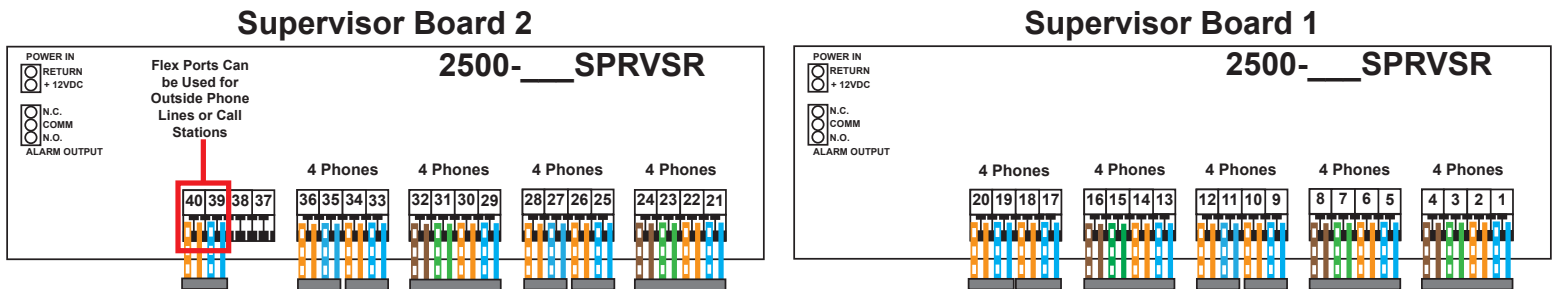

Note: Do not follow the color scheme on the punch down blocks themselves.

12-36 Zone Distribution Module Reference Wiring

- On top of each port there is a label indicating connection:
 - **STL** is the port used for connecting Emergency Phones
 - **TWT** is the port used for connecting outside Telco Lines
- The first card installed will always be:
 - Port 1: (01-04) connection for 4 Emergency Phones (SLT). Connects to Supervisor Board ports 1-4.
 - Port 2: (05-06) connection for 2 Telco Lines (TWT). Connects to last Supervisor Board ports 19-20.

Card 1 Example:

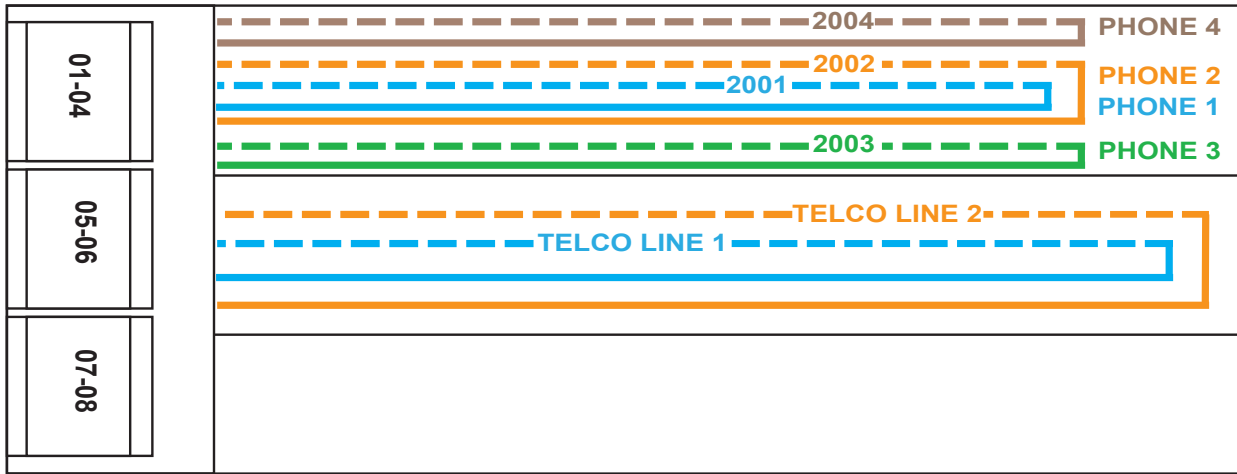

To punch down 19 or 20 on Supervisor Board (if using)

Note: Do not use the green and brown pairs

- The second through fifth cards will always be used for connecting additional Emergency Phones.

For Card 2:

- Port 1: (01-04) connection for 4 Emergency Phones. Connects to Supervisor Board ports 5-8.
- Port 2: (05-06) connection for 2 Emergency Phones. Connects to Supervisor Board ports 9-10.
- Port 3: (07-08) connection for 2 Emergency Phones. Connects to Supervisor Board ports 11-12.

Note: The numbering pattern continues on all subsequent cards. Depending on the number of zones needed, some cards will be left empty and will have no connections.

Card 2 Example:

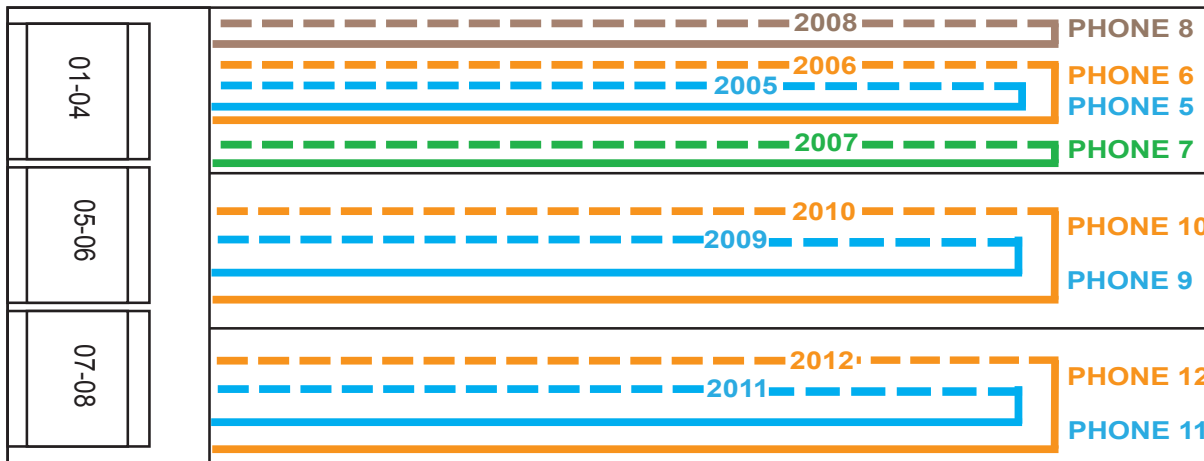

Note: Do not use the green and brown pairs

Wiring 56-96 Zone Systems

For 56 zone systems, three Supervisor Boards are included. Wire as shown below:

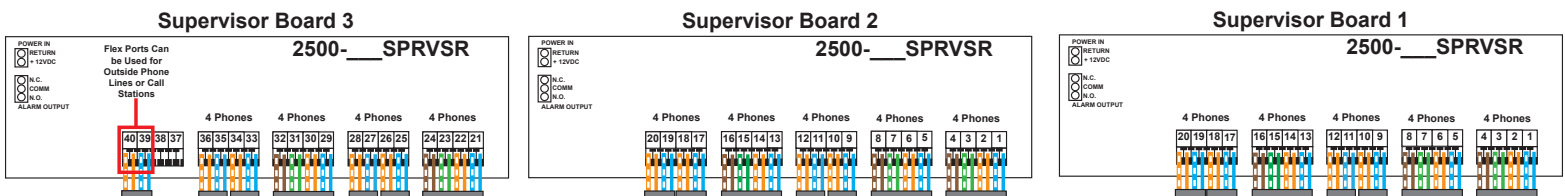

For 96 zone systems, five Supervisor Boards are included. Wire as shown below:

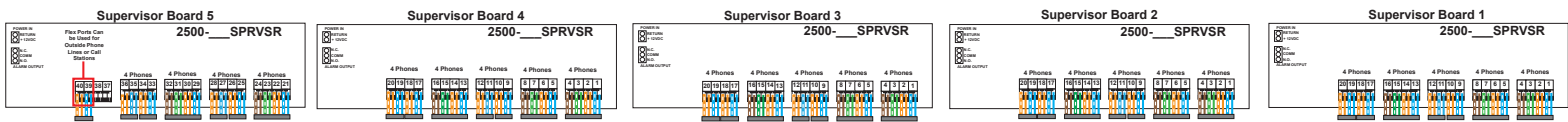

Note: Do not follow the color scheme on the punch down blocks themselves.

56-96 Zone Distribution Module Reference Wiring

- On top of each port there is a label indicating connection:
 - S01-S__** are the ports used for connecting Emergency Phones
 - TD(1-2)(3-4)** with a dot under the T is the port used for connecting outside Telco Lines
- The first card installed will always be:
 - Port 1: (S01-S04) connection for up to 4 Emergency Phones
 - Port 2: (S05-S08) connection for up to 4 Emergency Phones
 - Port 3: (S09-S12) connection for up to 4 Emergency Phones
 - Port 4: (S13-S16) connection for up to 4 Emergency Phones
 - Port 6: (T1-2) connection for up to 2 Telco Lines

Card 1 Example

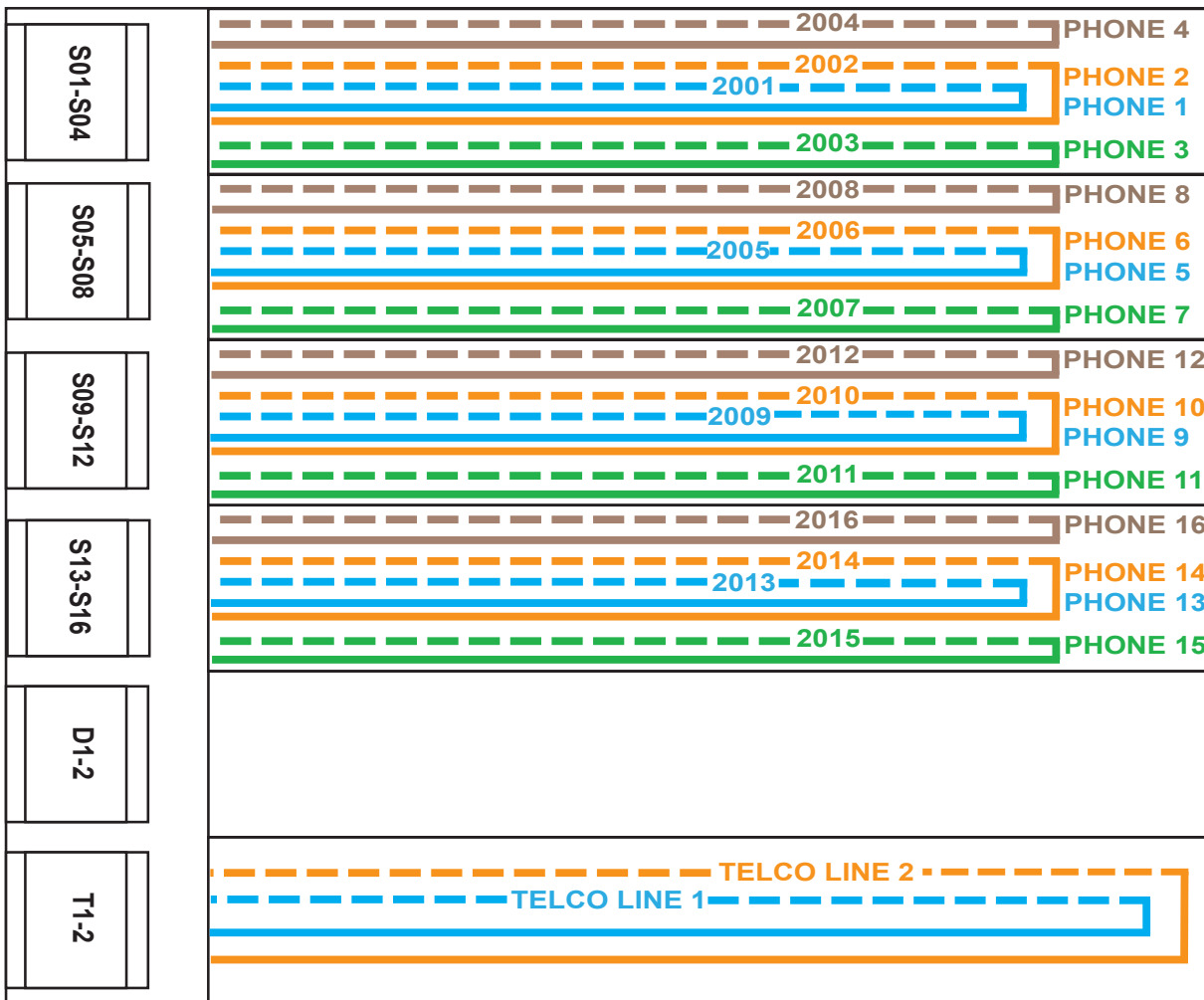

To punch down 19 or 20 on Supervisor Board (if using)

Note: Do not use the green and brown pairs

- Each additional card is used for connecting phones:
 - Port 1: (S01-S04) connection for up to 4 Emergency Phones
 - Port 2: (S05-S08) connection for up to 4 Emergency Phones
 - Port 3: (S09-S12) connection for up to 4 Emergency Phones
 - Port 4: (S13-S16) connection for up to 4 Emergency Phones
 - Port 5: (S17-S18) connection for up to 2 Emergency Phones
 - Port 6: (S19-S20) connection for up to 2 Emergency Phones

Note: The numbering pattern continues on all subsequent cards. Depending on the number of zones needed, some cards will be left empty and will have no connections.

Card 2 Example

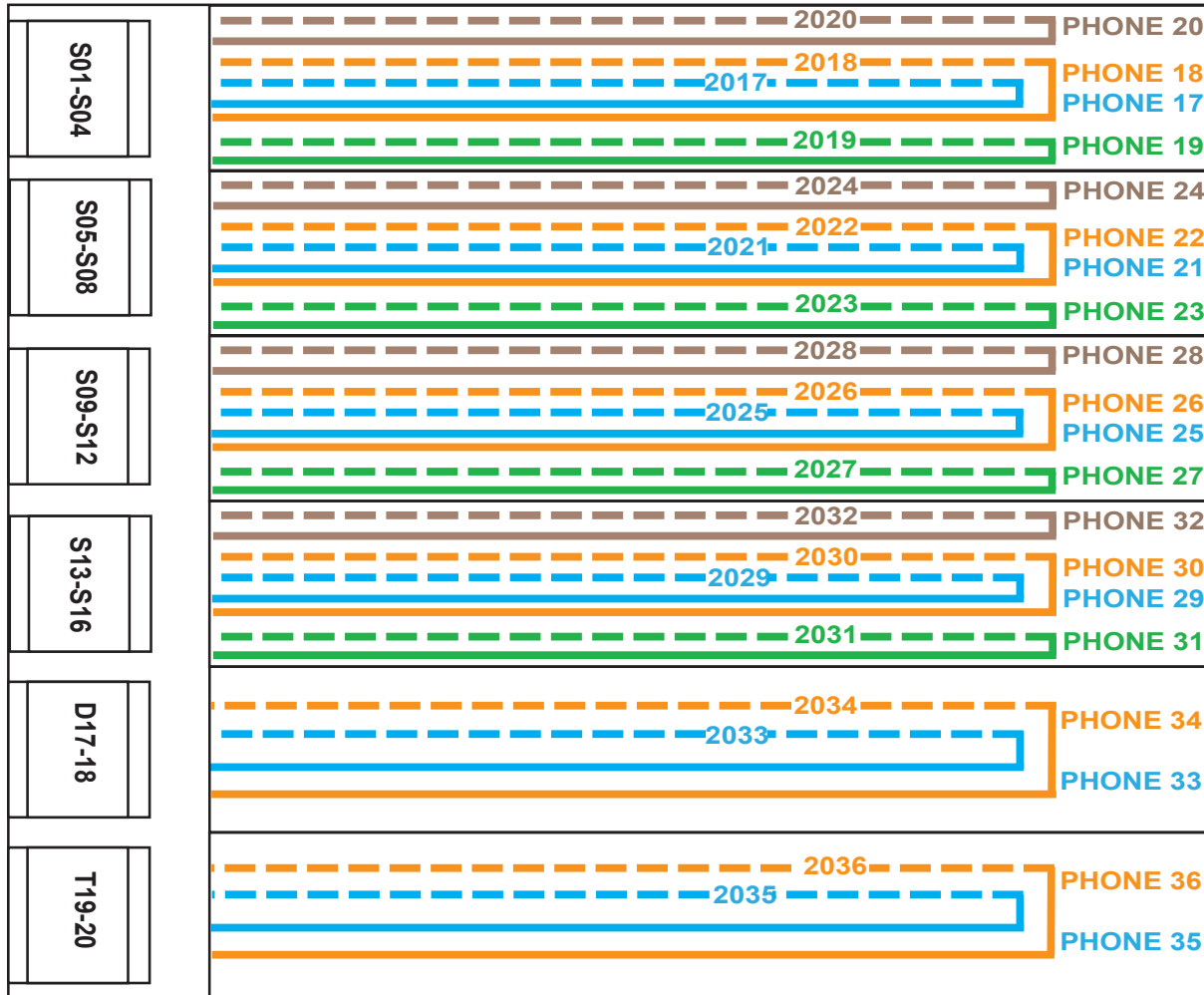

Note: Do not use the green and brown pairs

4. Secure the cables using the provided cable ties.

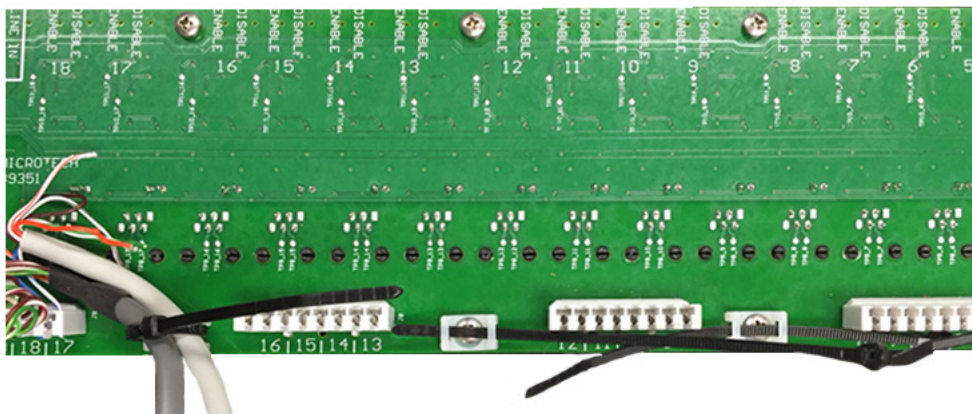

Wiring Call Boxes to Supervisor Board

1. Using the provided RJ11 pigtail cables, plug the RJ11 end of the cable into the RJ11 jack on the front of the Supervisor Board. The wire color on the jack should match what is punched down on the back.
2. Splice field station wiring on to pigtail sides of the RJ11 harness.
Note: The maximum wire run length is 4,000 ft.

Wiring Outside Phone Lines to Supervisor Board

Ports 19 and 20 on the Supervisor Board are flex ports. They can be used for emergency phones or outside phone lines.

1. Take one of the RJ45 wiring harnesses and connect the RJ45 side to the TWT port on the Distribution Module (refer to card break down to identify).
2. Follow one of the options below:
Note: If using multiple Supervisor Boards, it is recommended to use port 19 and/or 20 on the last board so the phone extensions are not out of order.
 - a. If using one phone line, use the 110 style punch down tool to punch down the blue, blue-white pair of wires on to the number 20 punch down block on the back of the Supervisor Board.
 - b. If using two phone lines, use the 110 style punch down tool to punch down the blue, blue-white pair on to the number 20 punch down block. Then, take the orange, orange-white pair and punch it down on to the number 19 punch down block on the back of the Supervisor Board.
3. Connect the phone line to the RJ11 jack on the front of the Supervisor Board that matches the same number wires that are punched down on the back of the board (Ex: Punch down block 20 = RJ11 port 20).
4. Change the dip switch on the top edge of the board to “LINE IN” and “ENABLE” on any port with a phone line connected to it.

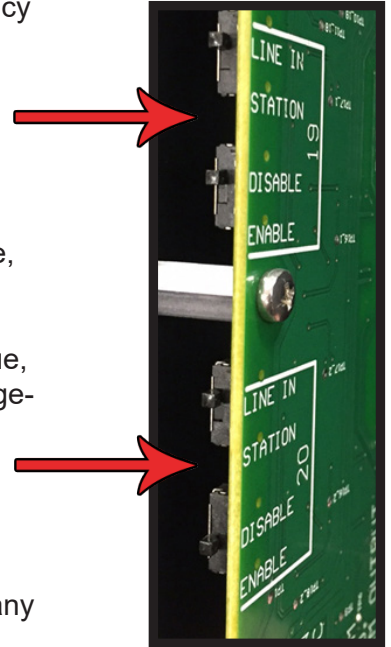

Connecting the Power Supply

Do not apply power to the Supervisor Board until all punch down connections are made.

1. Attach the supplied +12vdc Power Supply to the appropriate terminals on the Supervisor Board.
 - Insert the +Wire into the +Connector
 - Insert the -Wire into the RETURN Connector
 - Secure the wires by screwing down the capture clip

Note: For systems larger than 16 zones, connect the subsequent Supervisor Boards in series by connecting any additional wire to the +Connector and to the RETURN Connector for feeding power to the next board in the system. Wire up to 2 Supervisor Boards per transformer.

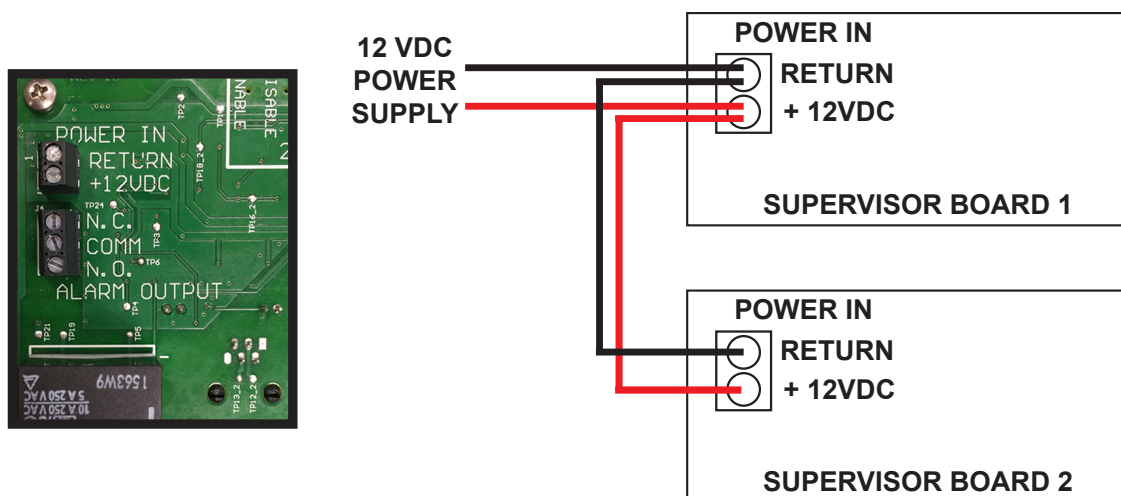

Setting Switches

The factory default setting for the switches is in the DISABLE position. Set the switches on all the monitored ports to the ENABLE position. Any port that has equipment connected to it should be monitored.

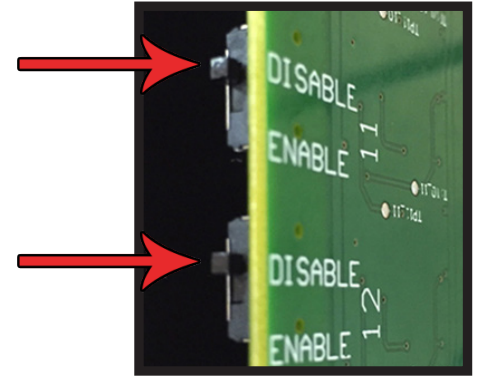

Setting Check Interval

1. Locate the “Test Interval” jumper on the back of the board.
2. The line check can be set to one of the following: 15 minutes, 6 hours, 12 hours, or 23 hours. Default is 15 minutes.
3. After determining desired time, move jumper so it vertically falls under the correct time.

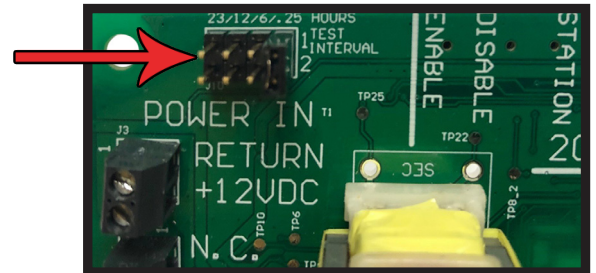

Alarm Wiring

An external device, such as a fire alarm panel, must be connected to the Supervisor Board for external fault notification. To do this, attach the wiring from the external device to the Normally Open (NO) or Normally Closed (NC) contacts of the notification relay.

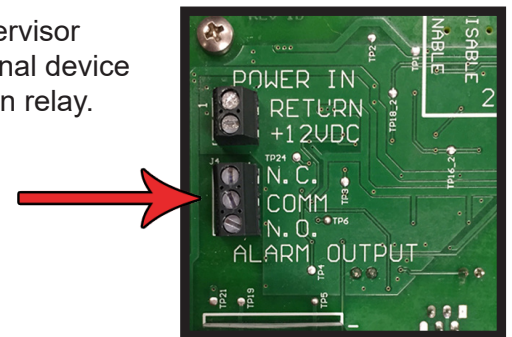

Mounting

Mount the Supervisor Board to a wall using the provided swing arm bracket or to a 19” rack (not included).

Complete System Connections

1. Plug the power transformer into the power source (wall outlet or UPS).
2. Ensure the LEDs associated with the connected Supervisor ports are NOT illuminated and the GREEN status light IS illuminated.

Note: When the unit powers on it will do a full check. This can take up to 90 seconds. Once the check is complete with no errors, the green system status light will illuminate.



Supervisor Board



UPS

Testing

Once all equipment is connected and power is applied, wait 30 minutes before testing.

1. Disconnect the RJ11s from the front of the Supervisor Board.
2. The LED above the port will illuminate.
3. The system will do a full check before the relay will change state. The duration of this test is determined by the timer jumper on the board plus 90 seconds (ex: If the timer jumper is set to 15 minutes, the relay will change after 15 minutes plus 90 seconds).
4. To reset, reconnect the RJ11 from the removed device. The red LED above the port will clear.
5. After all errored devices are reconnected, the green system status light should illuminate within 3 minutes.

Typical System Layout

